

HSS-DPS

EARLY-WARNING DEW-POINT SWITCH

PRODUCT DATA



APPLICATION

The HSS-DPS early-warning dew point switch is used to monitor the formation of condensation on chilled ceilings or to prevent condensation at critical spots of HVAC systems. It is also used as a dew point monitor for systems operating near the dewpoint.

The dew point switch measures the relative humidity near the dew point using its high-quality capacitive sensor. At reaching the switching point the output will provide an early warning signal for the initiation of control steps (increasing the initial water temperature, reducing the cooling capacity, switching on the heating, etc.). An additional status light indicates the condensation danger, as well as indicating power supply failure or broken cable.

Thanks to the special protection coating, sensor and electronics are highly insensitive to dust and dirt.

HSS-DPS dew point switch can be mounted on walls, ducts and pipes up to 50 mm (2").

FEATURES

- Does not wait to detect when the dew-point has already been reached, but rather provides an early warning of the approaching dew-point
- Compact design
- Fast response
- Module is coated, thus protected against contamination
- Simple and easy mounting
- Status light indicating condensation danger, power supply failure, or broken cable

SPECIFICATIONS

Supply voltage	24 VAC/VDC ±20%
Power consumption	< 10 mA (AC) / < 6 mA (DC)

Switch-points

RH > 90% ± 3%	contact "open" on clamp DRY, "closed" on clamp WET
RH < 90% ± 3%	contact "closed" on clamp DRY, "open" on clamp WET

Switching hysteresis	5% RH
Output	potential-free relay with changeover contact

Switching voltage	max. 24 VAC/DC
Switching current	max. 1 A

Response time at change of pipe/wall temperature	< 3 min
--	---------

Response time at change of relative humidity	< 25 s
--	--------

Weight	approx. 60 g
Operation temperature	0...+50 °C (+32...+122 °F)
Storage temperature	-20...+70 °C (-4...+158 °F)
Humidity	10...100% RH

Status indication	LED, red
Dust protection	by special coating (permeable for water vapor)

Housing protection class	IP40
Housing material	PC, fire resistant according UL94-V2

Approvals	CE
-----------	----

MOUNTING

Using the plastic wrap supplied with the shipment, the sensor should be mounted to that part of the pipe or of the flat chilled surface which is most susceptible to the formation of condensation water. The mounting location must be clean, dry, and bare (i.e. uninsulated). Remove the protective film on the adhesive tape before mounting. In mounting, it is important to provide for a good thermal contact between the sensor and the pipe or flat surface. The sensor is supplied in a pre-calibrated condition and thus need not be adjusted on site. In the case of pipes having a diameter in excess of 50 mm, use a correspondingly longer fastener (e.g., clamp metal band, etc.)

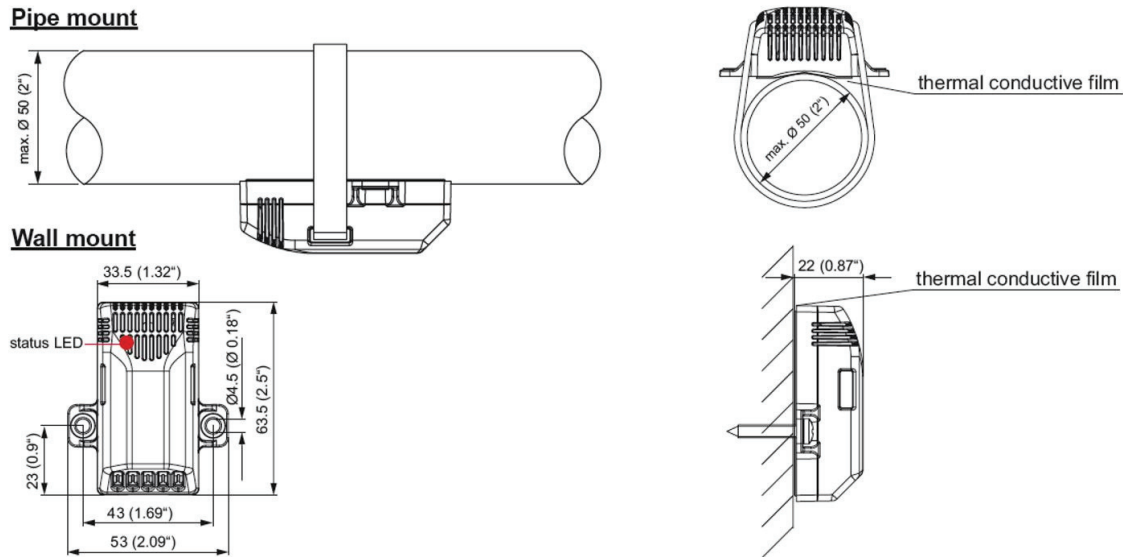

Fig. 1. Mounting (dimensions in mm)

CONNECTION

Electrical connection: 5-pole push-in terminal, max. 1.5 mm² (AWG 16)

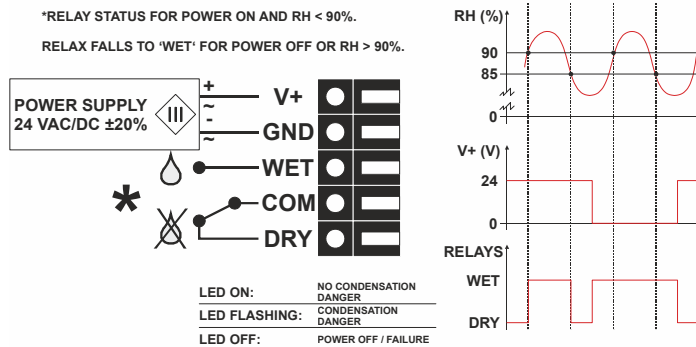

Fig. 2. Connection diagram of the HSS-DPS

Home and Building Technologies

Honeywell GmbH
Böblinger Strasse 17
71101 Schönaich, Germany
Phone +49 (0) 7031 637 01
Fax +49 (0) 7031 637 740
<http://ecc.emea.honeywell.com>